

SUPPORTI

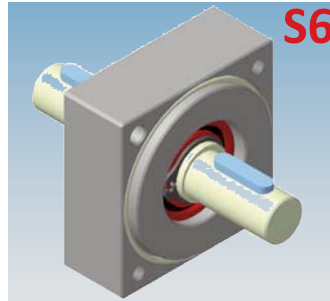

MODELLI DISPONIBILI



AVAILABLE VERSIONS

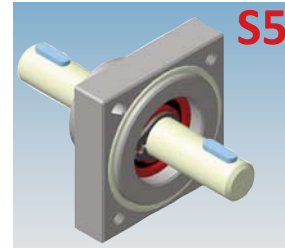

MODELLI DISPONIBILI

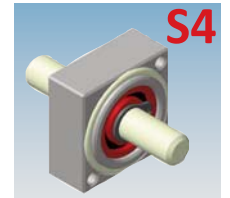

SUPPORTI FLANGIATI FLANGED SUPPORTS LAGERBÖCKE MIT FLANSCH

Supporti in alluminio flangiati (con flangia quadrata), con anello di tenuta o.ring e cuscinetti a sfera.

Disponibili alberi Ø8, Ø10, Ø14mm.

Possibilità di montaggio con fori filettati o fori per incasso viti.

Utilizzabili singolarmente su viti, chiocciolate, alberi oppure abbinabili alle nostre trasmissioni tipo "FAP" ed agli indicatori di posizione tipo "OP".

In particolare l'abbinamento con trasmissioni ed indicatori offre una soluzione semplice e completa per la movimentazione e visualizzazione del moto.

Flanged support units (with square flange) with o.ring, and ball-bearings.

Avialable shafts Ø8, Ø10, Ø14mm.

On request threaded bores or drillbores for screws. They can be used severally on screws, female screws, shafts or can be combined with our flexible shafts type "FAP" and our postion indicators type "OP".

Particularly the combination with flexible shafts and position indicators offers a simple and complete solution for handling and display of motion.

Flansch- Lagerböcke (vierkant-Flansche) mit O.Ring und Kugelgelagert.

Lieferbar mit Wellen Ø8, Ø10, Ø14mm Durchmesser.

Auf Anfrage Montage mit Gewindebohrungen oder mit Durchgangsbohrungen für Schrauben. Einzeln verwendbar auf Schrauben, Förderschnecken, Wellen oder

kombinierbar mit unsere flexible Wellen Typ "FAP" oder unsere Positionsanzeige Typ "OP".

Insbesondere die Kombination mit flexible Wellen und Positionsanzeigen, bieten eine komplette und einfache Lösung für die Verstellung und Anzeige von Bewegungen

Esempio di automazione
Automation example
Applikation

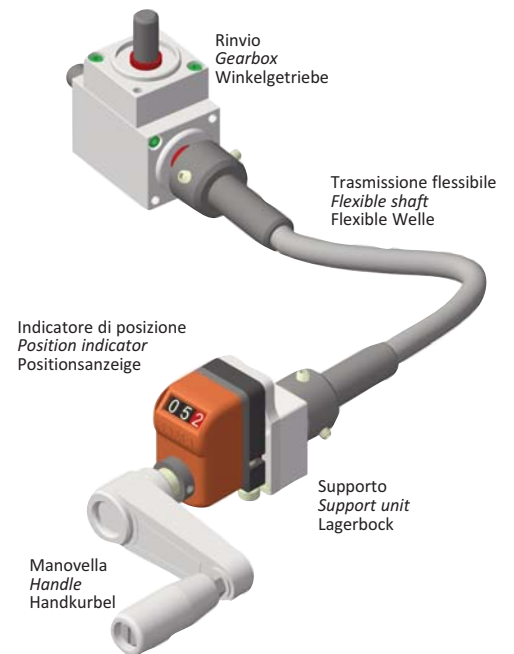

ESEMPI DI APPLICAZIONE CON INDICATORE DI POSIZIONE OP - APPLICATION EXAMPLES WITH POSITION INDICATOR OP - ANWENDUNGSBEISPIELE MIT POSITIONSANZEIGE OP

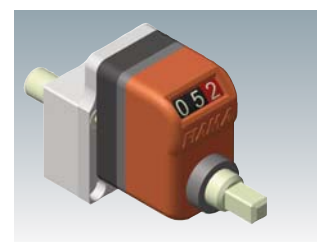
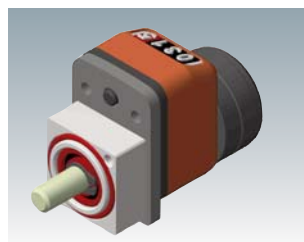
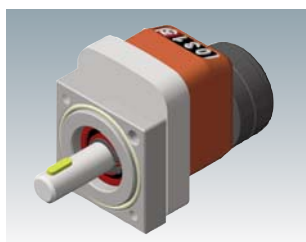
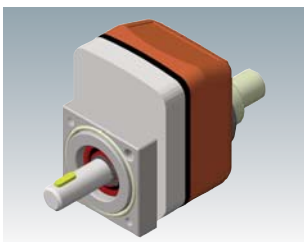

S4

S4 SUPPORTO CON ALBERO Ø8 - S4 SUPPORT UNIT WITH SHAFT Ø8 - S4 LAGERBOCK MIT WELLE Ø8

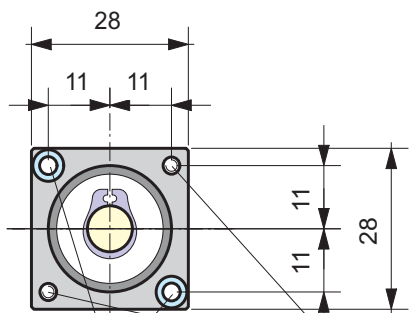

Ø4,2 con incasso Ø7,5X4,5 per vite brugola M3
 Ø4,2 rincer Ø7,5X4,5 pour vis Allen M3
 Ø4,2 con empotramiento Ø7,5X4,5 para tornillo Allen M3

Fori M3
 Bores M3
 Gewinde M3

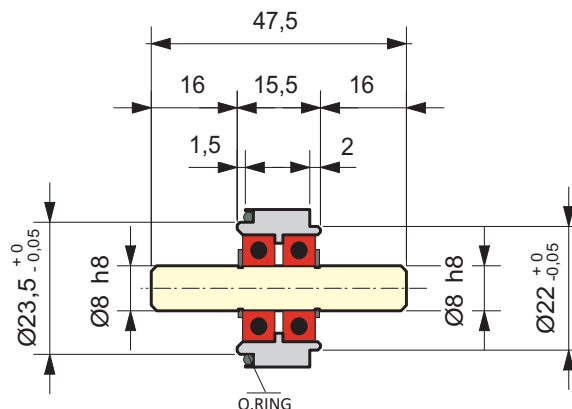

O.RING

S5

S5 SUPPORTO CON ALBERO Ø10 - S5 SUPPORT UNIT WITH SHAFT Ø10 - S5 LAGERBOCK MIT WELLE Ø10

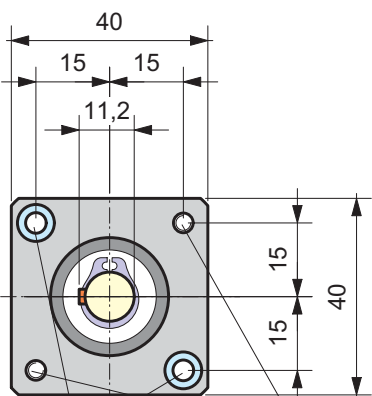

Ø4,2 con incasso Ø7,5X4,5 per vite brugola M4
 Ø4,2 drillbore Ø7,5X4,5 per for hex-screw M4
 Ø4,2 mit Bohrungen Ø7,5X4,5 für Inbus-Schrauben M4

Fori M4
 Bores M4
 Gewinde M4

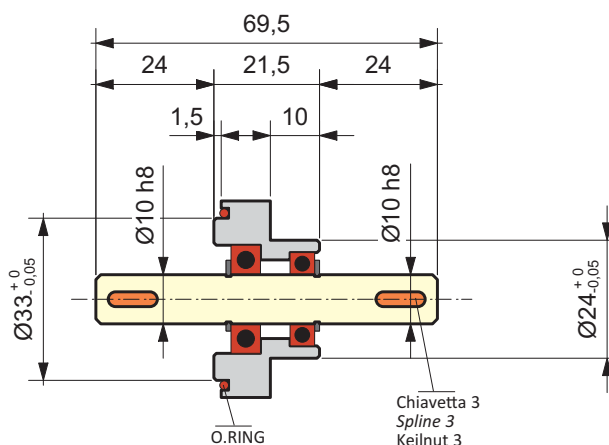

O.RING

Chiavetta 3
 Spline 3
 Keilnut 3

S6

S6 SUPPORTO CON ALBERO Ø14 - S6 SUPPORT UNIT WITH SHAFT Ø14 - S6 LAGERBOCK MIT WELLE Ø14

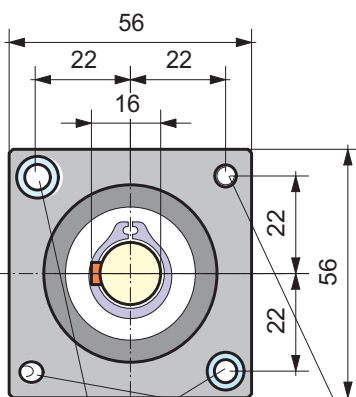

Ø5,2 con incasso Ø8,5X5,5 per vite brugola M5
 Ø5,2 drillbore Ø8,5X5,5 for hex-screw M5
 Ø5,2 mit Bohrungen Ø8,5X5,5 für Inbus-Schrauben M5

Fori M5
 Bores M5
 Gewinde M5

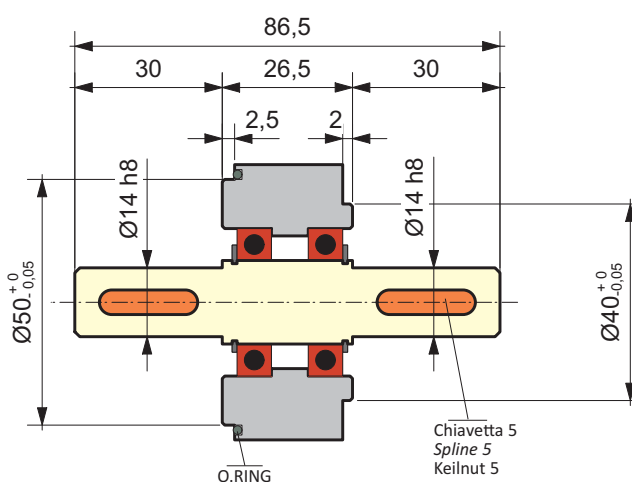

O.RING

Chiavetta 5
 Spline 5
 Keilnut 5

ESEMPIO DI ORDINAZIONE - PART NR. CONFIGURATION - BESTELLMUSTER:

S5

TIPO - TYPE - TYP

- S4 (28x28)
- S5 (40x40)
- S6 (56x56)